

File/Edition: KEY-R-B-SPC.001

Description: Push Button Switch

Customer Name:

Model No.: KEY (Series)

Customer P/N:

Toneluck P/N: KEY-R-B

Representative:

Project Code:

Specifications Receipt Confirmation

Received by: _____

Title: _____

Signature: _____

Date: _____

Remark:

1. This product specification is considered as the technical agreement between the receiving customer and Toneluck. Any information on the general product catalog which is in conflict with or different from the corresponding information of this document is considered as invalid.
2. If customer issue purchase orders without confirmation by signature of this specification after receipt, such confirmation will be considered as granted upon receipt of the first purchase order.

Prepared by: GanZhenXing2012-2-1Checked by: LiShuang2012-2-1Approved by: RayXu2012-2-1

Customer P/N:	Toneluck P/N: KEY-R-B	Project Code:
Product Version: A1	Issued Date: 2012-02-01	Page 1 of 5

1. General Characteristics

1.1 Application:	This specification is applied to the miniature quick switch for general applications.		
1.2 Operating Temperature Range :	-10°C to +60°C		
1.3 Operating Relative Humidity :	≤96% RH +40°C		
1.4 Test Conditions :	Unless otherwise specified, the atmospheric conditions for making measurements and tests are as follows :		
	Ambient Temperature :	5~35°C	
	Relative Humidity :	45~85%	
	Air Pressure :	86~106kPa (860~1060mbar)	

2.Appearance, Structure & Dimensions

2.1 Appearance:	The switch shall have good finishing, and no rust, crack or plating defects.
2.2 Structure & Dimensions:	Refer to individual product drawing.
2.3 Markings:	Refer to individual product drawing.

3.Ratings & Life

Ratings	Operating life with load
Refer to individual product drawing	

4.Electrical Characteristics

X	Item	Criteria	Test Method
4.1	Contact Resistance	50mΩ Max.	Shall be measure at 1A, 5V DC by voltage drop method.
4.2	Insulation Resistance	100MΩ Min.	500VDC voltage is applied between each pair of terminals and between the terminal and the metal frame for 60±5s.
4.3	Dielectric Voltage	No dielectric breakdown shall occur.	500VAC (50~60Hz, cut-off current 2mA) is applied between non-connected terminals and between terminals and the metal frame for 60±5s.

5.Mechanical Characteristics

X	Item	Criteria	Test Method
5.1	Operating Force	Refer to individual product drawing	A static load shall be applied to the tip of actuator in operating direction.
5.2	Travels	Refer to individual product drawing	
5.3	Terminal Strength	<ul style="list-style-type: none"> - Shall be free from terminal looseness, damage and insulator breakage. - The electrical performance requirements specified in section 4 shall be satisfied. 	A static load of 10N shall be applied to the tip of terminal in a desired direction for 1 min. The test shall be done once per terminal.

Customer P/N:	Toneluck P/N: KEY-R-B	Project Code:
Product Version: A1	Issued Date: 2012-02-01	Page 2 of 5

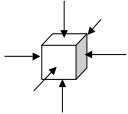
5.4	Strength of operating section	-Shall be free from pronounced wobble bending and mechanical abnormalities.	-A static load of 30N shall be applied in the operating direction for 15s. -A static load of 30N shall be applied in the pulling direction for 15s. -A static load of 30N shall be applied in the perpendicular direction of operation at the tip of actuator for 15s.						
5.5	Vibration Proof	After test, - Contact resistance: 100mΩ Max. - Insulation Res.: 50MΩ Min. - Electrical performance requirements specified in item 4.3 shall be satisfied. -Operating force: Within ±10% of specified value. -No abnormalities shall be recognized in appearance and construction.	Switch shall be secured to a testing machine by a normal mounting device and method. Switch shall be measured after following test. (1) Vibration frequency range = 10~55 Hz (2) Total amplitude = 1.5mm (3) Sweep ratio: 10~55~10Hz Approx. 1 min. (4) Method of changing the sweep vibration frequency : logarithmic or linear (5) Direction of vibration: Three perpendicular directions including actuating direction. (6)Duration :2 hours @ (6 hours in total)						
5.6	Mechanical Shock	After test, - Contact resistance: 100mΩ Max. - Insulation Res.: 50MΩ Min. -Electrical performance requirements specified in item 4.3 shall be satisfied. -Operating force: Within ±10% of specified value. -Shall be free from mechanical abnormalities.	Switch shall be measured after following test : (1) Mounting Method : Normal (2) Acceleration : 100m/s ² (10G) (3) Duration : 11 ms (4) Test Direction : 6 directions  (5)Number of shocks :3 times per direction (18 times in total)						
5.7	Solderability	-Terminal More than 90% of immersed part shall be covered with solder.	Switch shall be checked after following test : (1) Soldering Temperature : 260±5°C Immersing Time : 3±0.5 s Flux immersing time shall be 5~10s in normal room temperature. (2) Immersion Depth : Immersion depth shall be at copper plating portion of PCB after mounting. (Thickness of PCB = 1.6mm)						
5.8	Solder Heat Resistance	-No abnormalities shall be observed in appearance and operation. -The electrical performance requirements specified in item 4 shall be satisfied.	Switch shall be measured after following test : (1) Soldering Temperature & Immersing Time <table border="1" data-bbox="978 1749 1422 1834"> <tr> <td>Dip Soldering</td> <td>260±5°C</td> <td>5±1s</td> </tr> <tr> <td>Manual Soldering</td> <td>350±10°C</td> <td>3~4s</td> </tr> </table> (2) Immersion Depth:(For Dip Soldering) Immersion depth shall be at copper plating portion of PCB after mounting. (Thickness of PCB = 1.6mm.)	Dip Soldering	260±5°C	5±1s	Manual Soldering	350±10°C	3~4s
Dip Soldering	260±5°C	5±1s							
Manual Soldering	350±10°C	3~4s							

Customer P/N:	Toneluck P/N: KEY-R-B	Project Code:
Product Version: A1	Issued Date: 2012-02-01	Page 3 of 5

6. Durability Characteristics

X	Item	Criteria	Test Method
6.1	Operating Life with Load	After test, - Contact resistance: 200mΩ Max. - Insulation Res.: 10MΩ Min. - Electrical performance requirements specified in item 4.3 shall be satisfied. - Operating force shall be within ±20% of specified value. - The switch shall be free from abnormalities in appearance & construction.	100,000 cycles of operation shall be performed continuously at a rate of 15~30 cycles per minute with load as 0.01A 35VDC.

7. Weather Proof Characteristics

X	Item	Criteria	Test Method
7.1	Cold Proof	After test, - Contact resistance: 200mΩ Max. - Insulation Res.: 10MΩ Min. - Electrical performance requirements specified in item 4.3 shall be satisfied. - Operating force shall be within ±10% of specified value. - The switch shall be free from abnormalities in appearance & construction.	After testing at $-25\pm 3^{\circ}\text{C}$ for 96 hours, the switch shall be allowed to stand under normal temperature and humidity conditions for 1 hour, and measurement shall be made within 1 hour after that. Water drops shall be eliminated.
7.2	Hot Proof		After testing at $70\pm 2^{\circ}\text{C}$ for 96 hours, the switch shall be allowed to stand under normal temperature and humidity conditions for 1 hour, and measurement shall be made within 1 hour after that.
7.3	Moisture Resistance		After testing at $40\pm 2^{\circ}\text{C}$, 90~95% RH for 96 hours, the switch shall be allowed to stand under normal temperature and humidity conditions for 1 hour, and measurement shall be made within 1 hour after that. Water drops shall be eliminated.
7.4	Temperature Cycling		After 5 cycles of following conditions, the switch shall be allowed to stand under normal temperature and humidity conditions for 1 hour, and measurement shall be made within 1 hour after that. Water drops shall be eliminated.

Customer P/N:	Toneluck P/N: KEY-R-B	Project Code:
Product Version: A1	Issued Date: 2012-02-01	Page 4 of 5

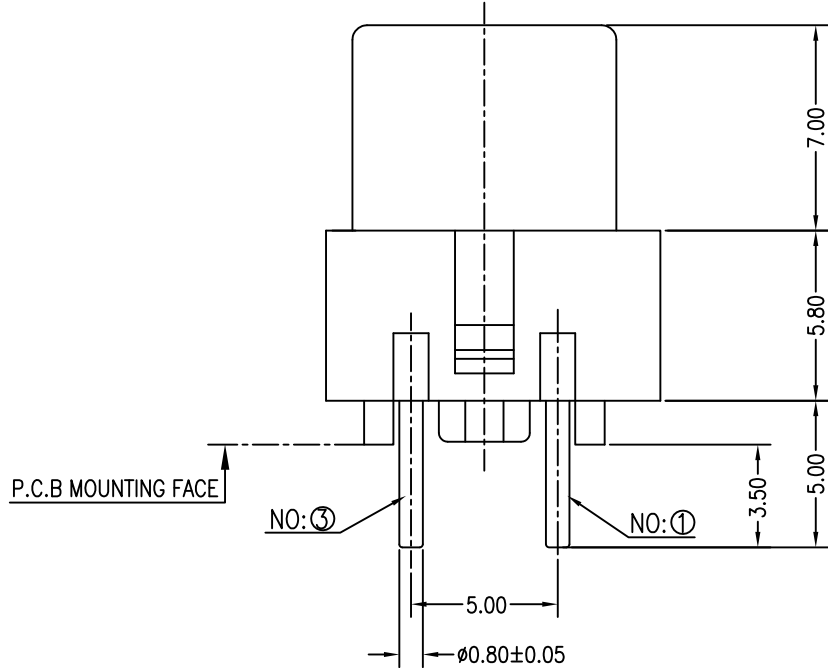
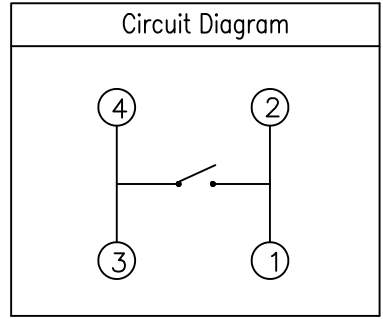
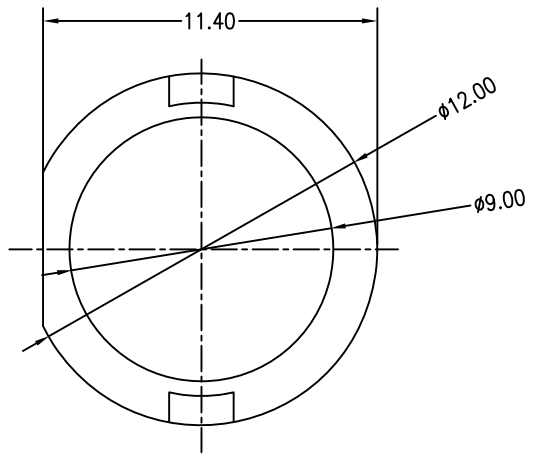

Specifications	
Item	Criteria
Pre Travel	0.80 mmMax
Operating Force	130±50 gf
Ratings:	0.01A/35VDC
Contact Resistance:	50mΩ Max
Insulation Resistance:	100MΩ Min
Operating Life :	100,000 cycles with load .
Operating Temperature:	-10°C~+60°C
Dielectric:	500VAC(50~60HZ) - between non-connected terminals for one minute - between terminals and dead parts

Cap	R-BLACK
Base	WH
Terminal	
Part Name	Description

MASS PRODUCTION RELEASE

Project Ref:	KEY Push Button Switch	Tolerance Unless Otherwise Specified							
Part No:	KEY-R-B	<3	>3~10	>10~30	>30~80	>80~180	Angle		
Drawing No:	- - -	Eng Ver	A1	±0.20	±0.30	±0.40	±0.60	±0.80	±3°
Drafted by:	HeShiyang	Date:	2011-01-07	Unit: mm	Size: A4	Scale:			
Checked by:	LiShuang	Date:	2011-01-07	THIRD ANGLE	 Switches & Control Solutions				
Approved by:	RayXu	Date:	2011-01-07						